

Paper

Step-Wake Stabilized Jet Flame in a Transverse Air Stream

ISHIDA Hiroki*

Abstract

The stabilization and the shape characteristics of a jet flame behind a backward facing step were studied experimentally. The effects of experimental parameters; airflow velocity, position of fuel jetport, velocity of fuel jet, the step dimensions, on the flame stability (blow off condition) and the flame shape characteristics were examined in detail. It was shown that the recirculation and shear flow zones behind the step and the balance of momentum between fuel jet and airflow have strong effects on the stability and the shape of flame.

Introduction

Flame stabilization in high-speed flow is a key process in many industrial combustion chambers. For proper flame stabilization in the combustion chamber, a certain and stable zone of lower flow velocity than the characteristic burning velocity must exist [1~6]. Many studies on the flame stabilization in high speed flow field therefore have been performed both theoretically and experimentally since over forty years ago. In some industrial combustion chambers it is needed to decrease the number of inserted parts of devices in the flow path for avoiding the structural complexity. For this reason, novel flame stabilization technique has been investigated recently. One new technique is a fuel injection into the flow path behind a backward facing step on the combustion chamber wall [7,8,9]. The mechanism of flame stabilization behind the backward facing step, however, has not been clarified sufficiently yet owing to the complex flow field around the step and to some differences in the experimental conditions in many studies [7~16]. The velocity of transverse air stream, the position and velocity of fuel jet, and the dimension of step characterize the recirculation and shear flow zones behind the backward facing step. The recirculation

and shear flow zones have large effects on the flame shape and the stability. The present study aims to examine experimentally the effects of these factors on the flame shape and the stabilization characteristics behind the step in a transverse air stream.

Apparatus and Procedure

Figure 1 shows a schematic illustration of the flow field behind the step. In a transverse air stream (average airflow velocity: V_a) from the square duct (75mm×75mm), fuel jet (Methane or Propane) behind the step was ignited. The fuel jetport (diameter: 1~2mm) was positioned at the distance L from the step (height: H). In the experiment, the average airflow velocity was increased up to 30 m/s, the fuel jet velocity V_f was 5 ~ 60 m/s, the distance L was 8~60 mm, and the step height H was 15~40 mm.

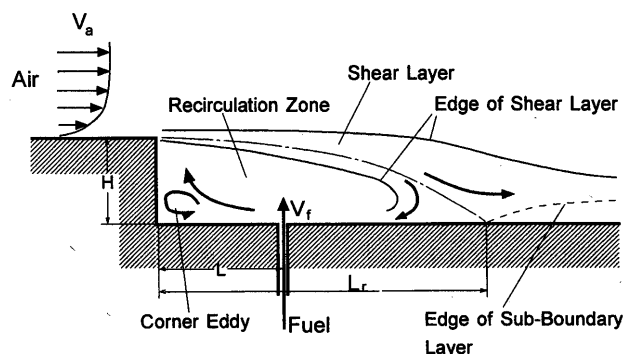
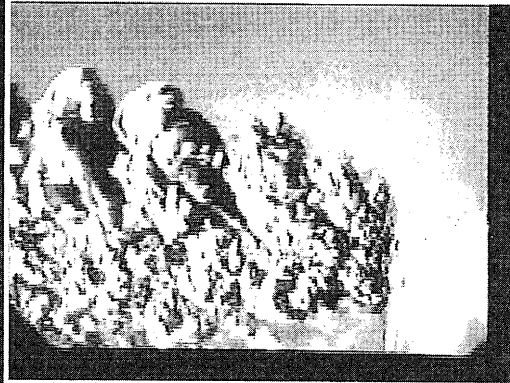

Figure 1: Flow Field near Fuel Jetport behind the Step.

Propane

H=30mm, L=20mm, $\phi = 1.0\text{mm}$

$V_a = 12.5\text{m/s}$



$V_f = 36.09\text{m/s}$
($\alpha_v = 2.89$)

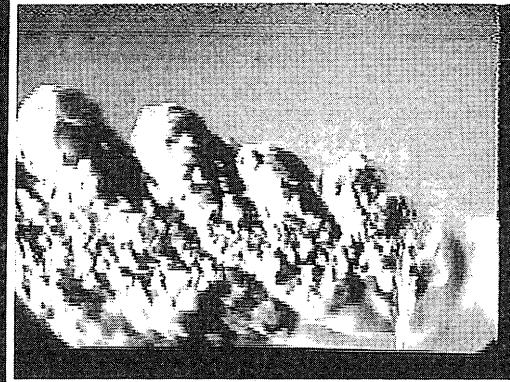
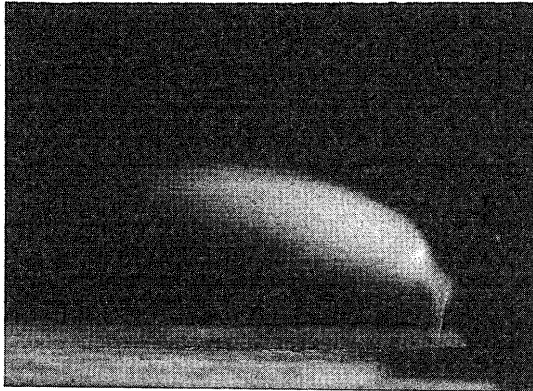

$V_f = 25.48\text{m/s}$
($\alpha_v = 2.04$)

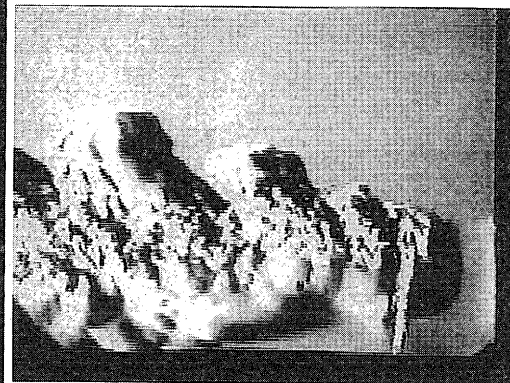
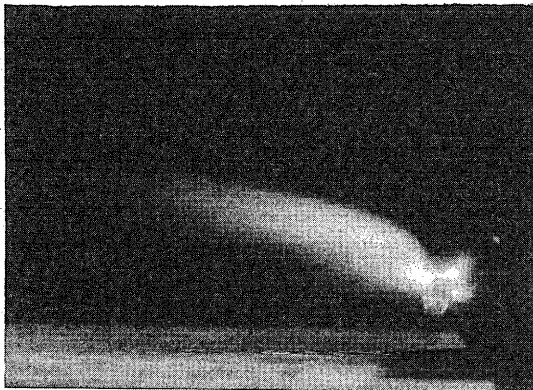

$V_f = 14.86\text{m/s}$
($\alpha_v = 1.19$)

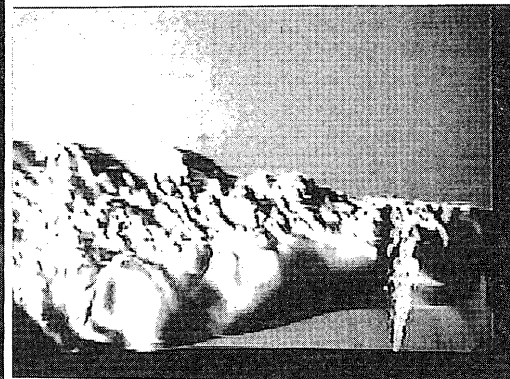

$V_f = 10.62\text{m/s}$
($\alpha_v = 0.85$)

Figure 2: Direct and Schlieren Photographs of Propane Jet Flame behind the Step.
H=30mm, L=20 mm, $V_a = 12.5\text{m/s}$.

The shape and the behavior of flame were recorded by Schlieren photography, video camera, and direct still camera. Shutter speeds were 1/8~1/15 sec in direct photography, and 1/10000 sec in schlieren photography.

The influences of the velocities of the airflow and the fuel jet step height, fuel jet port position and fuel density on flame stabilization and flame shape characteristics were examined in detail.

Results and Discussion

[1] Flame Shape Characteristics

Figure 2 shows direct and schlieren photographs of stabilized propane jet flames. We can see that with decrease in the fuel jet velocity, the base of flame above the jetport is pulled toward the step owing to the momentum of the recirculation flow behind the step, and thereby the shape of stabilized flame is to be changed. In the shear flow layer behind the step, the flame is fanned and stretched strongly downstream. The characteristics of the stability and the shape of turbulent jet flame in the shear layer have offered many interesting and important subjects of study of combustion. From these instantaneous schlieren images, we can infer the instantaneous local wave shape of flame front in the shear layer.

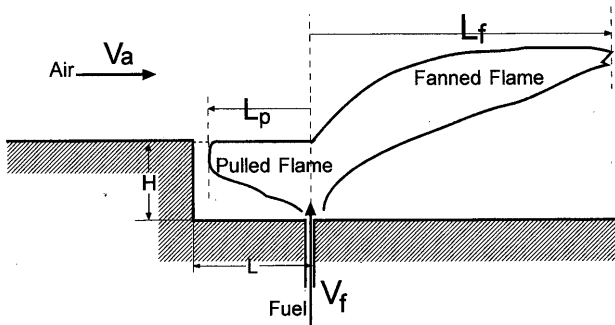

Figure 3: Schematic Illustration of Jet Flame Shape behind the Step.

Schematic illustration of typical shape of the jet flame stabilized behind the step is shown in Figure 3. The flame is pulled upstream (the length: L_p) by the recirculation flow, and is also fanned downstream (the length: L_f) in the shear flow layer. To examine the factors affecting the shape of stabilized flame in detail, lengths of L_p and L_f were examined. Figure 4 shows the nondimensionalized length of pulled flame (L_p/L) affected by airflow velocity; V_a , fuel jet

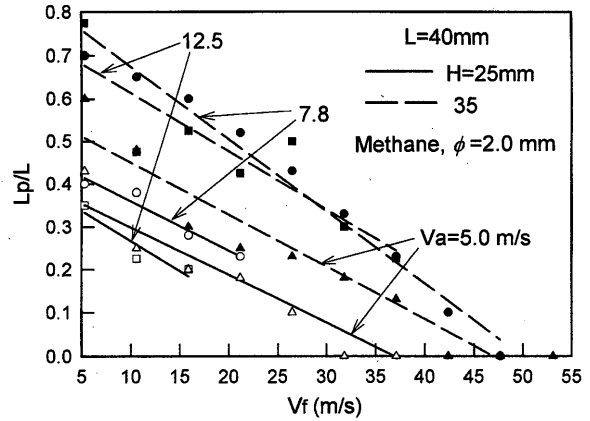

Figure 4: Influencing Factors on the nondimensional Length of Pulled Flame; L_p/L .

velocity; V_f and step height; H . In general, L_p decreases with increase in V_f , and increases with increases in H . Also, L_p/L decreases with increase in L , but increases with increase in the airflow velocity. These results show clearly the importance of the balance of momentum between the fuel jet (vertical) and the recirculation flow behind the step (horizontal).

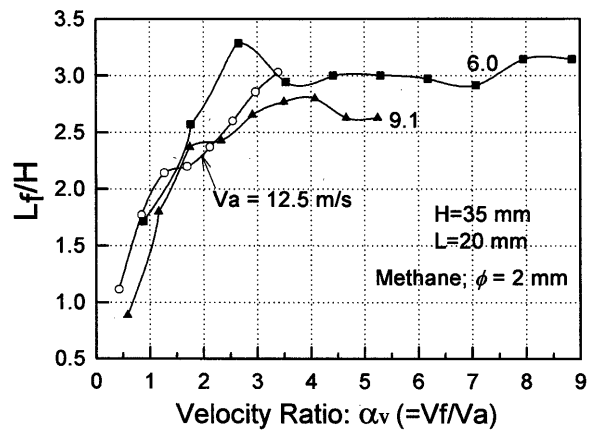

Figure 5: Influencing Factors on the nondimensional Length of Fanned Flame; L_f/H .

Figure 5 shows the nondimensionalized length of fanned flame (L_f/H) affected by V_a and by the velocity ratio $\alpha_v (=V_f/V_a)$. The length of fanned flame increases to some extent with increase in α_v , but gradually reaches the maximum (nearly constant) value. Namely, we can see that there is a limitation for the length of fanned flame in the shear flow layer behind the step.

From these results we can expect also the effect of fuel density (momentum of fuel jet) on both of L_p

and L_f . To confirm this, difference in L_p and L_f due to the jets of methane and propane were compared, where the density of propane is about 2.8 times that of methane. The effects of the difference in the magnitude of fuel jet momentum on L_p/L and on L_f/H for methane and propane are clearly shown in Figures 6 and 7.

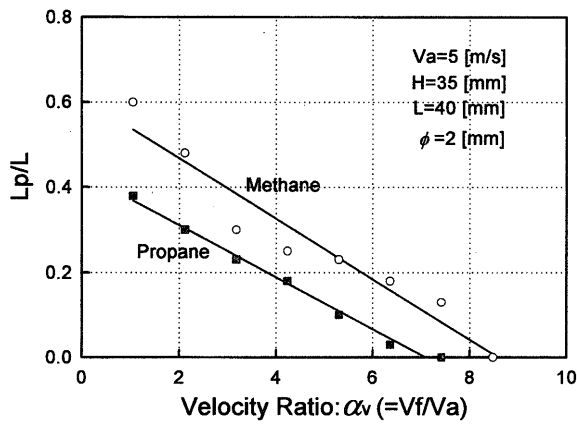

Figure 6: Effect of the Velocity Ratio of Fuel Jet to that of Airflow on L_p/L for Methane and Propane.

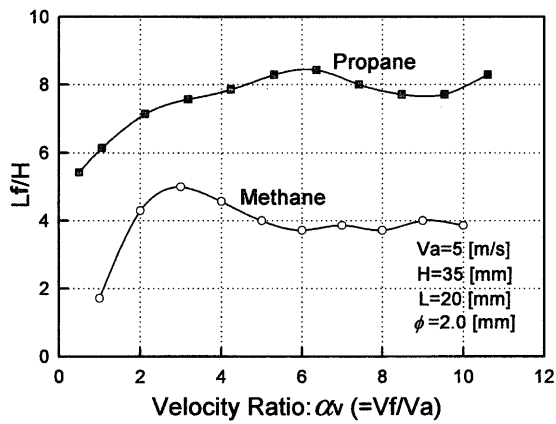

Figure 7: Effect of the Velocity Ratio of Fuel Jet to that of Airflow on L_f/H for Methane and Propane.

The length of pulled flame of propane is shorter than that of methane, and the length of fanned flame of propane is longer than that of methane. These are all clearly due to the difference in the magnitude of jet momentum (fuel density) between propane and methane.

[2] Stability of Flame

It should be noted here that the jet flame can be stabilized behind the step even at high fuel jet

velocity; about three times the transverse airflow velocity. Without the transverse airflow the jet flame must be blown off. The results clearly show the important role of the recirculation flow behind the step for flame stabilization in high velocity flow field.

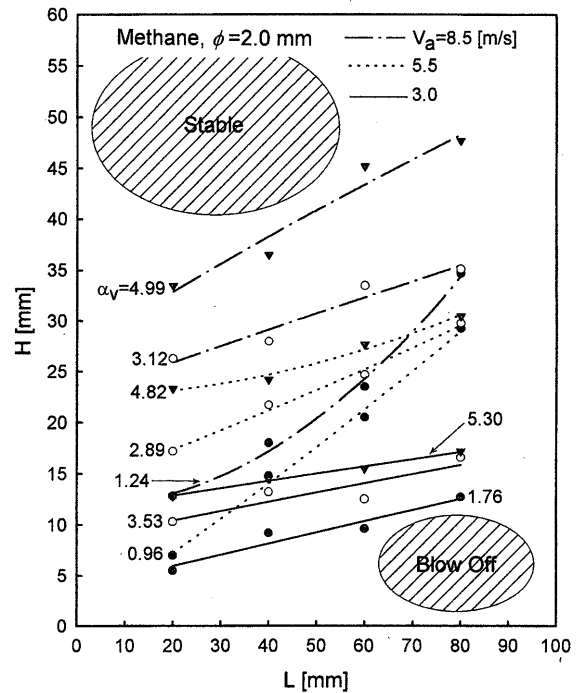

Figure 8: Flame Stabilization Map by H and L .

Figure 8 shows the flame stabilization map by the step height (H) and the fuel jet position (L), where the flame is stabilized in the region above each line, but is blown off in the region under each line. As is shown, the flame stability increases with increase in H and with decrease in L for each airflow velocity V_a . The step must become higher with increase in the velocity ratio; α_v . Namely, for the flame stabilization, with increase in the fuel jet velocity, the step must become higher and the position of fuel jetport must become closer to the step. Figure 9 shows the flame stabilization map by the velocities of airflow (V_a) and fuel jet (V_f) with comparison of propane and methane, and by the difference in the momentum of fuel jet due to the jetport diameter; 1 and 2 mm. In this map we can see the interesting peninsula curves of the flame stabilization zone. It should be noted here also that for methane, the range of airflow velocity for the flame stabilization is widened by the enlarged jetport (2 mm in diameter), while the inverse result is shown for propane. These results are all due to the

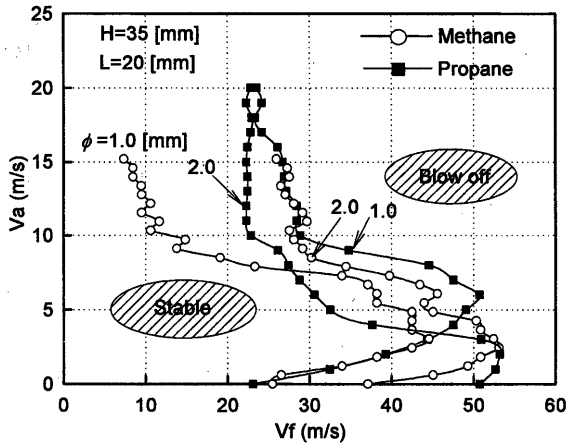

Figure 9: Flame Stabilization Map by the Velocities of AirFlow (V_a) and Jets (V_f) of Propane and Methane.

difference in the balance of momentums of the fuel jet, the recirculation flow and the shear flow behind the step.

From the results shown in these peninsula curves, we can obtain the schematic relation map between V_a and V_f for flame stabilization as shown in Figure 10.

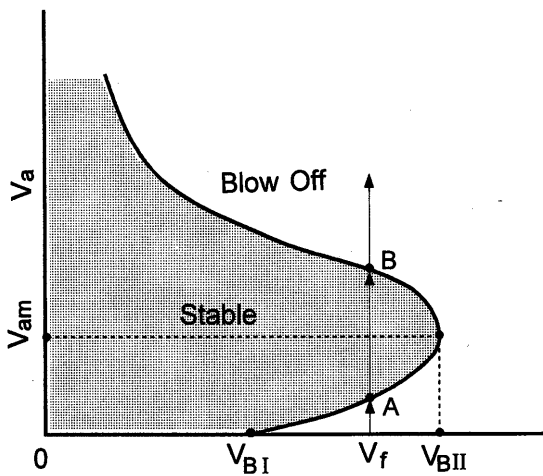

Figure 10: Schematic Map of Flame Stabilization by V_a and V_f .

Without the transverse airflow, namely $V_a = 0$, the jet flame is to be blown off if the fuel jet velocity (V_f) is over V_{BI} . When the airflow is given at the velocity over **A**, however, the flame can be stabilized owing to the sufficient recirculation flow behind the step, even at the fuel jet velocity over V_{BI} . At the more increased airflow velocity over **B**, however, the flame is blown off owing to too strong recirculation flow and too high velocity airflow in the shear layer. Although there are

many studies on the structure and stability of jet flame in the shear flow layer, including the concept of *flame stretch*, there still exist many unsolved subjects of study owing to the complicated phenomena. In the present study, as shown in the instantaneous schlieren images, a stable recirculation zone of high temperature burned gas must be produced behind the step for stabilizing the wave-like flame front.

For stabilization of jet flame of which the fuel jet velocity is over V_{BI} , the airflow velocity must be in the appropriate range accordingly; from **A** to **B**. In addition, with increase in the fuel jet velocity the possible range of the airflow velocity for flame stabilization becomes narrow. This result suggests that the fuel jet velocity supporting the flame stabilization can be increased up to the maximum; V_{BII} when the airflow velocity reached the critical value; V_{am} .

For the flame stabilization in the wake of bluff body in combustible gas mixture flow, it is well known that the flow velocity at the blow off of flame is approximately proportional to the product of pressure, dimension of bluff body and the square of burning velocity [6]. This is based on the concept that the flame will be blown off when the combustion reaction can not finish by the end border of recirculation flow zone in the wake. Namely, the flame can be stabilized when the ratio of the characteristic flow time of combustible gas mixture to the ignition delay time; *the first Damkohler number* is more than unity in the recirculation flow zone in the wake.

In the present study, we can see very interesting result, as shown in Figure 11, that the critical airflow

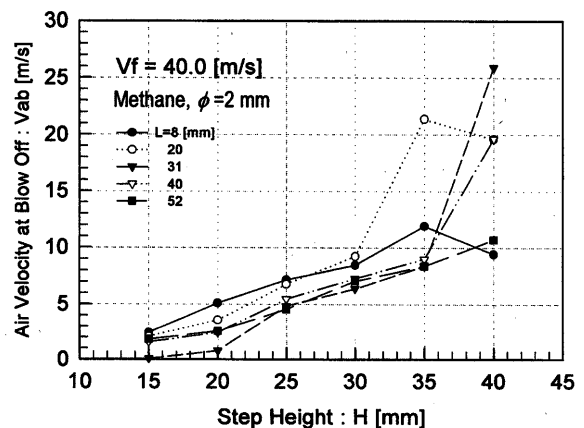

Figure 11: Relationship between the Step Height and the Critical Airflow Velocity at Flame Blow off.

velocity at blow off; V_a at **B** in **Fig. 10** is approximately in the first order linear relation with the step height (**H**) up to about 30mm. The stabilization mechanism of the jet flame in the present study, of course, should be discussed further together with both characteristic flow fields of shear layer and recirculation zone. The results shown in this study suggest that successful stabilization of the pulled flame (shown in **Fig. 4**) by the recirculation zone behind the step must be the dominant factor for the flame stabilization. In some recent studies on the flame stabilization behind the step, it is shown that the strong turbulence in the shear flow layer will disturb the stable recirculation zone behind the step leading to the blow off of the flame [9].

Concluding Remarks

- (1) The shape of stabilized flame behind the backward facing step strongly depends on the balance of momentums between fuel jet and recirculation flow. Successful formation of the recirculation zone behind the step is dominant factor for the flame stabilization.
- (2) The flame length in the shear flow layer behind the step increases with increase in the fuel jet velocity, but gradually settles at the maximum and constant value.
- (3) For the flame stabilization, the velocities of airflow and fuel jet must be in their proper ranges. The step must be appropriately high, and the fuel jetport must be positioned appropriately close to the step.
- (4) In the nearly first order linear relation, the critical velocity of airflow at the blow off of flame increases with increase in the step height.

Acknowledgments

The author wishes to express his sincere thanks to Mr. K. Hirokawa of machine facility for his great help in setting up the experimental apparatus.

References

- (1) Choudhury P.R. and Cambel A.B., *Flame Stabilization by Wall Recesses*, Proc. of 8th Symposium on Combustion, International, 1960, pp.963-970
- (2) Tsuji H., *Flame Stabilization in High Speed Flow (in Japanese)*, J. of Japan Soc. for Aeronautical and Space Sci., Vol.10, No.99, (1962) 122-133
- (3) Kawamura T, *Fuel Jet Flame in Shear Layer behind the Step (in Japanese)*, Proc. of JSME, Vol.35, No.269, (1969) 127-142
- (4) Eaton K.J. and Johnston J.P., *A Review of Research on Subsonic Turbulent Flow Reattachment*, AIAA J. Vol.19, No.9, (1981) 1093-1100
- (5) Keller J.O., Vaneveld L., Korschelt D., Hubbard G.L., Ghoniem A.F., Daily J.W. and Oppenheim A.K., *Mechanism of Instabilities in turbulent Combustion Leading to Flashback*, AIAA Journal, Vol.20, No.2, (1982) 254-262
- (6) F.A.Williams, *Combustion Theory*, Benjamin / Cummings Pub. Corp. Inc. p.508-, (1985)
- (7) Raghunandan B.N. and Yogesh G.P., *Recirculating Flow over a Burning Surface-Flame Structure and Heat Transfer Augmentation*, Proc. of 23rd Symposium. on Combustion, International, 1988, pp.1501-1507
- (8) Takebe M., Tsukamoto T., Hasegawa S. and Niioka T., *Flame Stabilization in Case of Fuel injection at Downstream of Backward-facing Step (in Japanese)*, Proc. of JSME (B), vol.58, No.545 (1992) 236-241
- (9) Harinaldi, Ueda T. and Mizomoto M, *Holding of Diffusion Flame in the wake of Step (in Japanese)*, Proc. of 34 th Symposium on Combustion, Japan, (1996) 481-483
- (10) Huang R.F. and Wang S.M, *Characteristic Flow Modes of Wake-Stabilized Jet Flames in a Transverse Air Stream*, Comb. and Flame, Vol. 117, (1999) 59-77
- (11) Takahashi F., Schmoll W.J., Strader E.A. and Belovich V.M., *Suppression of a Nonpremixed Flame Stabilized by a Backward-Facing Step*, Comb. and Flame, Vol. 122, (2000) 105-116
- (12) Coats C.M. and Richrdson A.P., *Nonpremixed Combustion in Turbulent Mixing Layers Part I: Flame Characteristics*, Comb. and Flame, Vol. 122, (2000) 253-270
- (13) Coats C.M., Richrdson A.P. and Wang S., *Nonpremixed Combustion in Turbulent Mixing Layers Part 2: Recirculation, Mixing and Flame Stabilization*, Comb. and Flame, Vol. 122, (2000) 271-290

- (14) W. Grosshandler, et al.; *Suppression of A Non-Premixed Flame behind A Step*, Proc. of 28th Symp. on Comb, Int'l, p.2957-, (2000)
- (15) F. Takahashi, et al.; *Suppression Behavior of Obstruction-Stabilized Pool Flames*, Comb. Sci. and Tech., Vol. 163, p.107-, (2001)
- (16) J.M. Cohen, B.E. Wake and D. Choi; *Investigation of Instabilities in a Lean, Premixed Step Combustor*, Journal of Propulsion and Power, Vol.19, No.1, (2003)